

Particolari stampati in materiale termoplastico: rif Din 16901
 Particolari tranciati in metallo: rif. UNI EN 22768
 - grado IT10 per dimensioni lineari
 - grado IT11 per quote di piega
 - angoli di piega $\pm 1^\circ$
 Particolari lavorati alle macchine utensili: rif. UNI EN 22768

Tolleranze generali

Note:

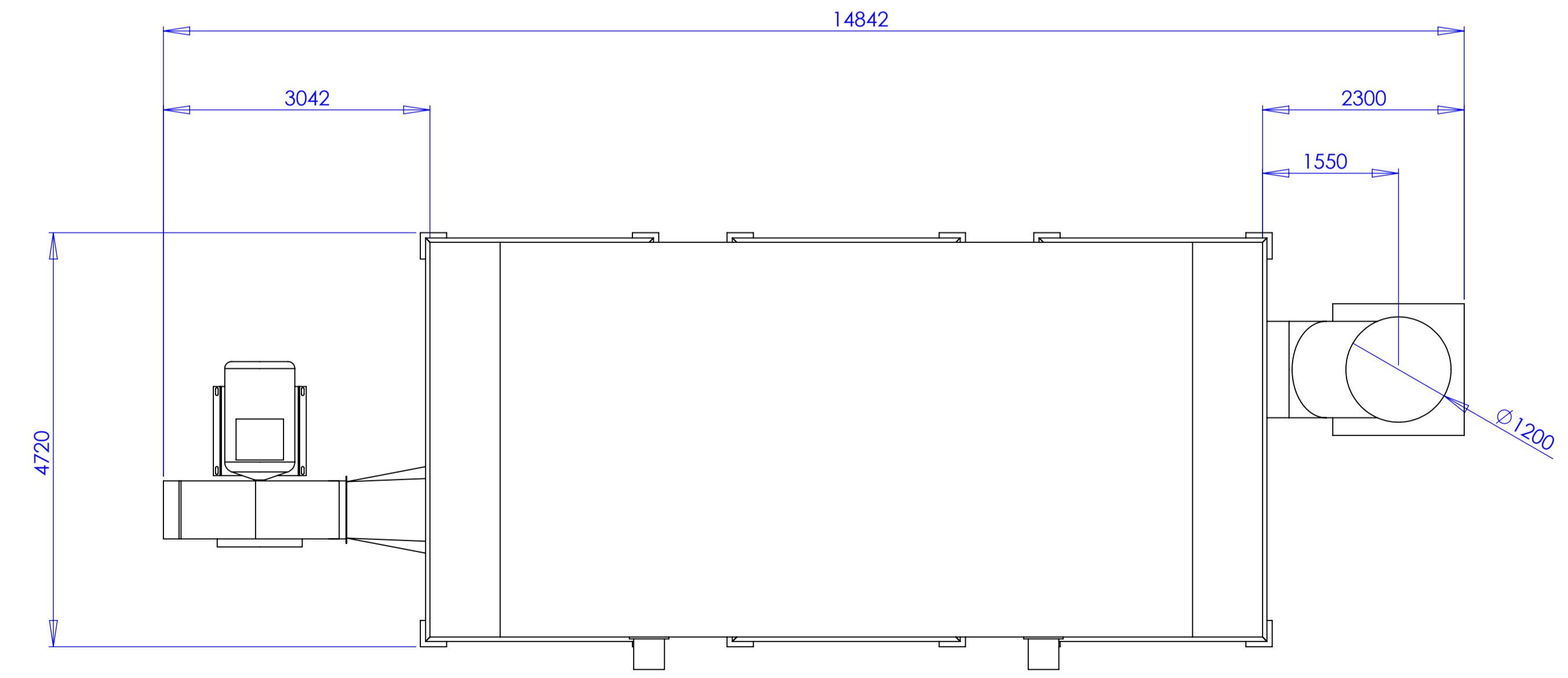
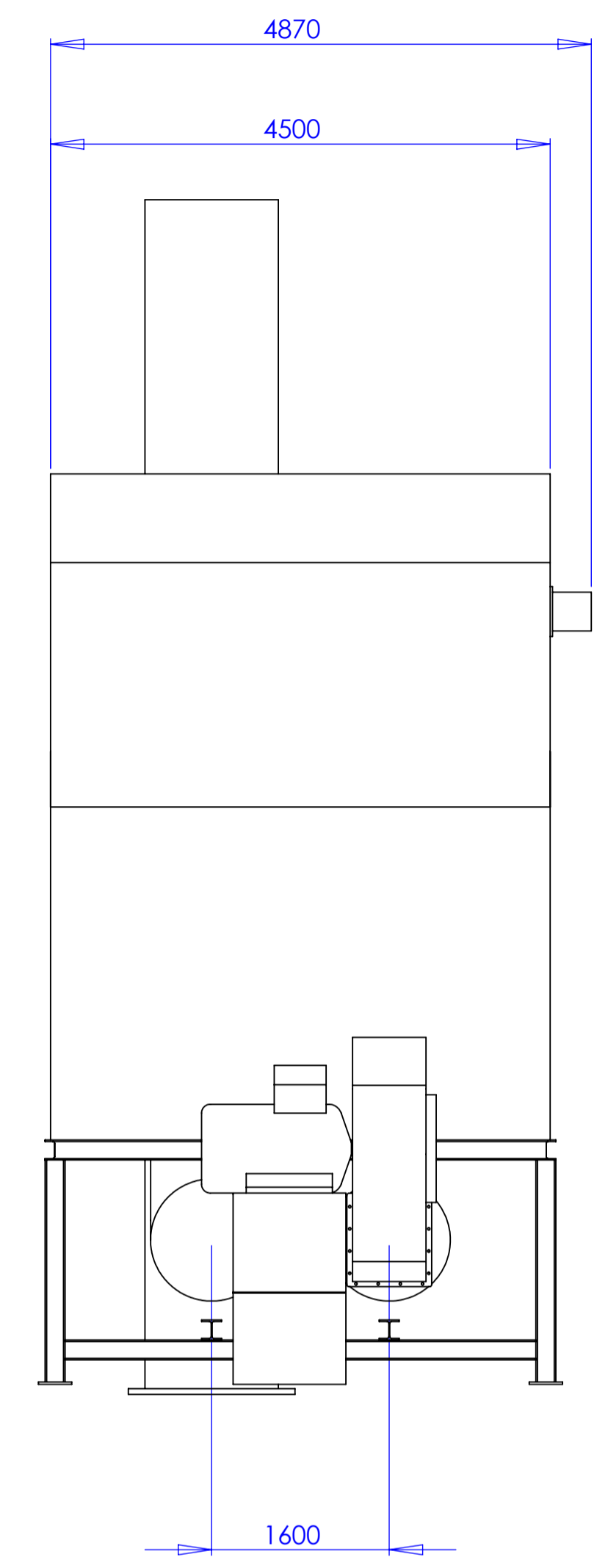
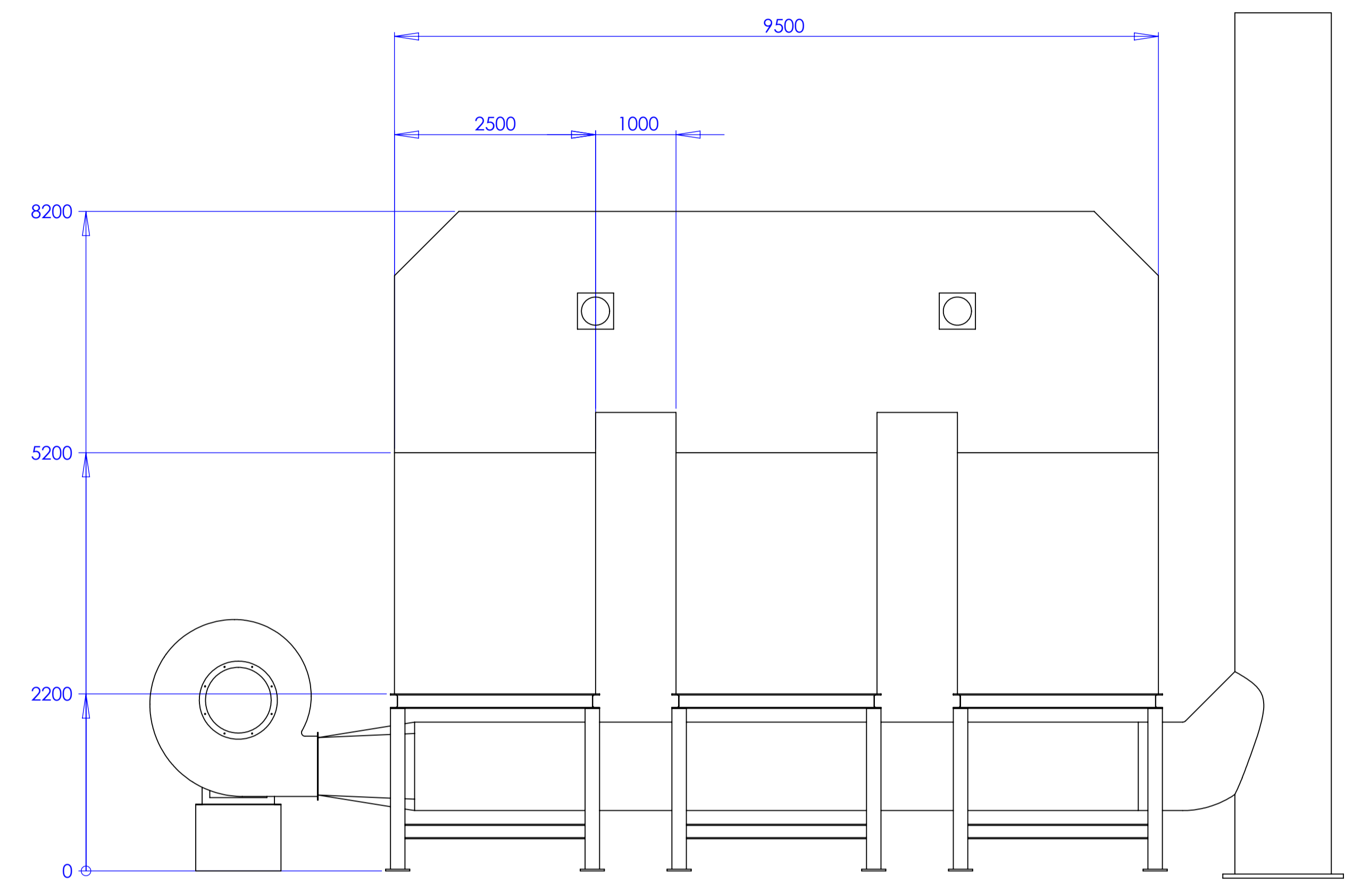
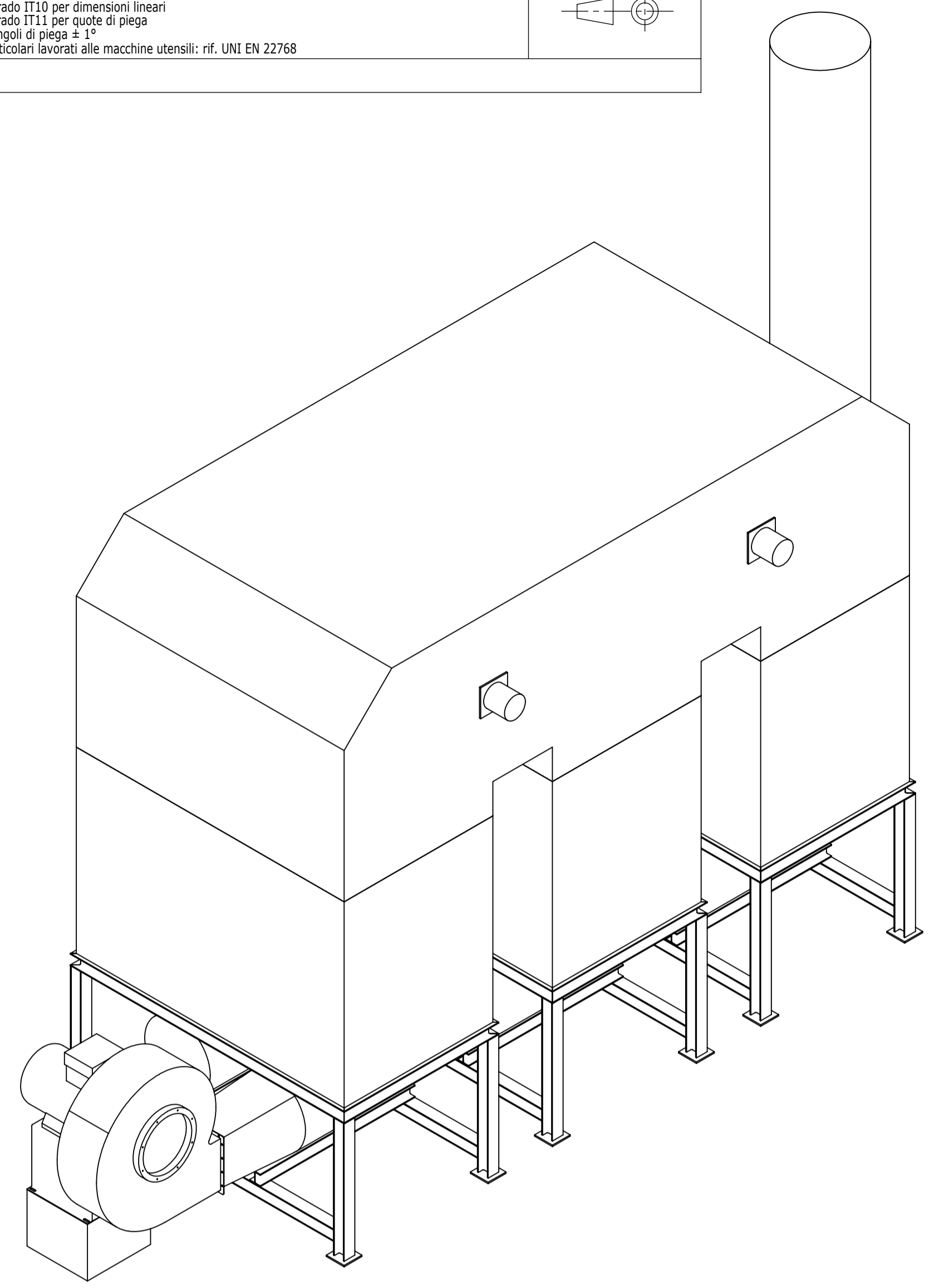
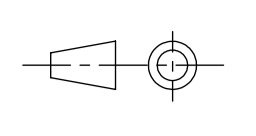

tecama Tecam Soluciones Medioambientales S.L.
 C/Berruguete 110, Local A8 08035 Barcelona
 ☎ +34 93 428 11 54 / 📠 +34 93 428 16 73 / 🌐 www.tecamgroup.com

Rev.	Date	Description of modification	Drawn by
-	-	-	-
-	-	-	-
-	-	-	-

Filename: S-08-018-000_RTO_25000	Weight (g): --	Treatment: -
Material: -	Scale: 1:50	Project: TECAM
Drawn by: A.MODOLO	Date: 18/07/2008	Formet: AQ
Checked by: -	Sheet N°: 1	Rev: -
Title: RTO 25000	Sheet N°: 1	Rev: -
	Drawing N°: S-08-018-000	